

FRONT VIEW

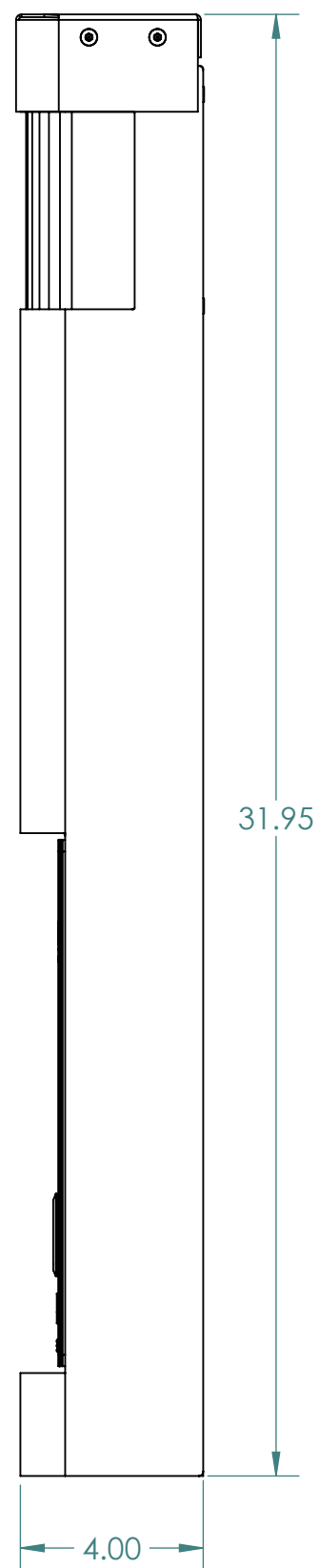

SIDE VIEW

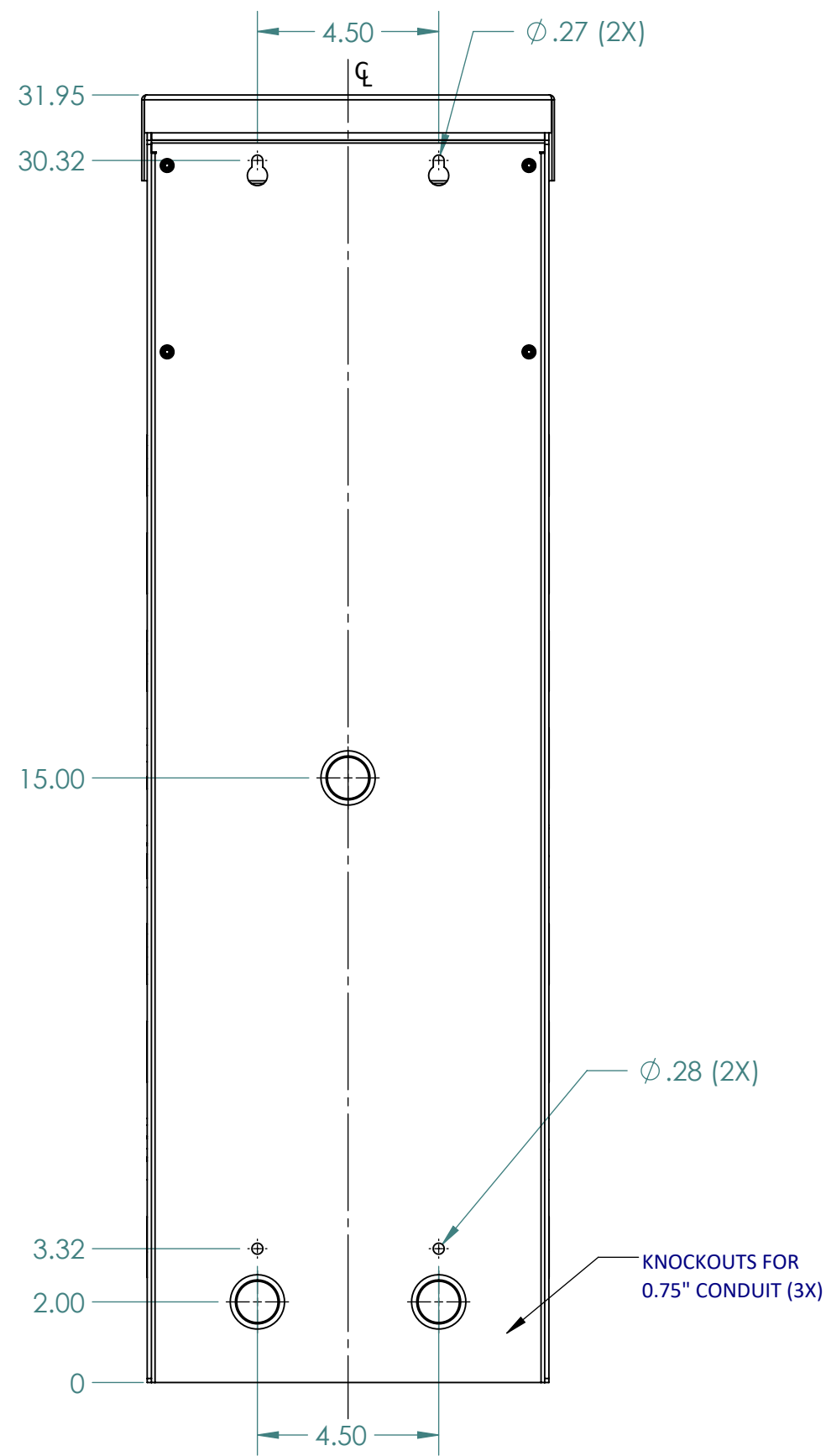

REAR VIEW

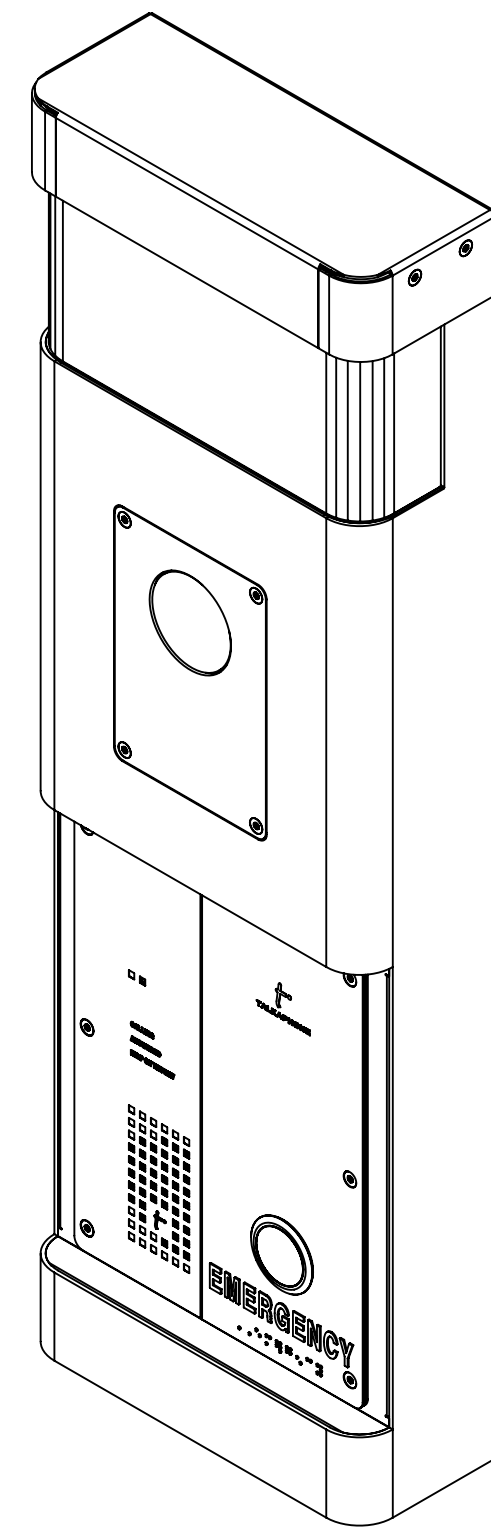

ISOMETRIC VIEW

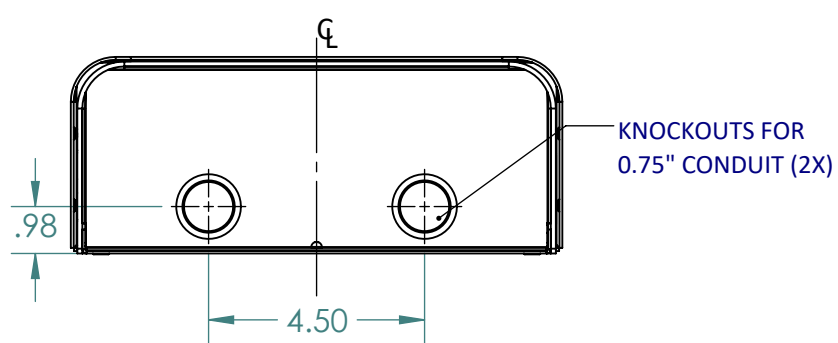

BOTTOM VIEW

-OP2:
 INCLUDES A HOUSING FOR MOUNTING YOUR OWN FIXED CCTV CAMERA (STAND FORM FACTOR WITH MAXIMUM CAMERA DEPTH OF 3.5 IN.) INSIDE THE WALL MOUNT ABOVE THE EMERGENCY PHONE FACEPLATE. INQUIRE FOR FURTHER DETAILS

-OP3IP:
 INCLUDES AN AXIS M1025 NETWORK CAMERA INSIDE THE WALL MOUNT ABOVE THE EMERGENCY PHONE FACEPLATE.

1.2
1.1

REV.	DESCRIPTION	DATE	APPROVED
1.2	ADDED WALL_MOUNTING SHEET	7/26/2017	K PATEL
1.1	ADDED CAMERA MOUNT SHEET	7/26/2016	M OBAL
1.0	MARKETING RELEASE	03/16/2016	K PATEL

REVISIONS			
NAME	DATE		
DRAWN K PATEL	03/16/2016		
CHECKED C WONG	03/16/2016		
ENG APPR.			
MFG APPR.			
Q.A.			
COMMENTS:			

TALKPHONE
 TALK-A-PHONE CO.
 7530 N. NATCHEZ AVE., NILES, IL 60714
 WWW.TALKPHONE.COM

FINISH
 PROPRIETARY AND CONFIDENTIAL
 THE INFORMATION CONTAINED IN THIS DRAWING IS THE SOLE PROPERTY OF TALK-A-PHONE COMPANY. ANY REPRODUCTION IN PART OR AS A WHOLE WITHOUT THE WRITTEN PERMISSION OF TALK-A-PHONE COMPANY IS PROHIBITED.

SIZE	PART NO.	ETP-WMS-OP2/OP3IP	REV
C	DWG. TITLE:	ETP-WMS SERIES	1.2
SCALE: 1:8	WEIGHT:	SHEET 1 OF 4	

8

7

6

5

4

3

2

1

F

E

D

C

B

A

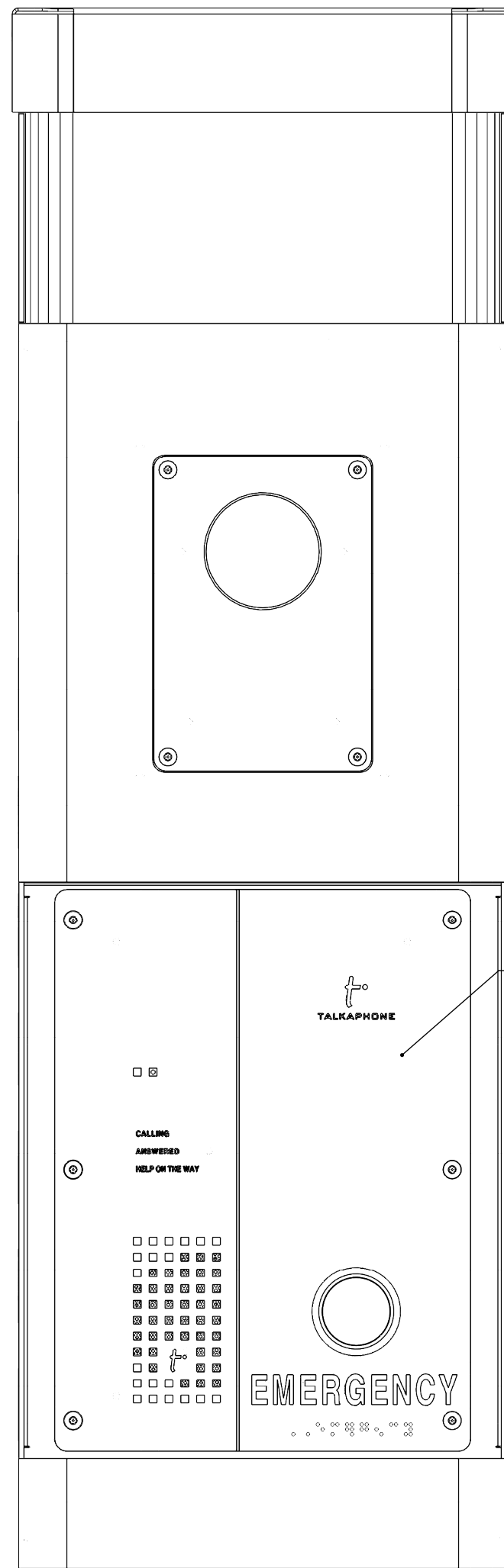

FRONT VIEW

SHOWN WITH VOIP-600 SERIES CALL STATION FOR ILLUSTRATION PURPOSES ONLY

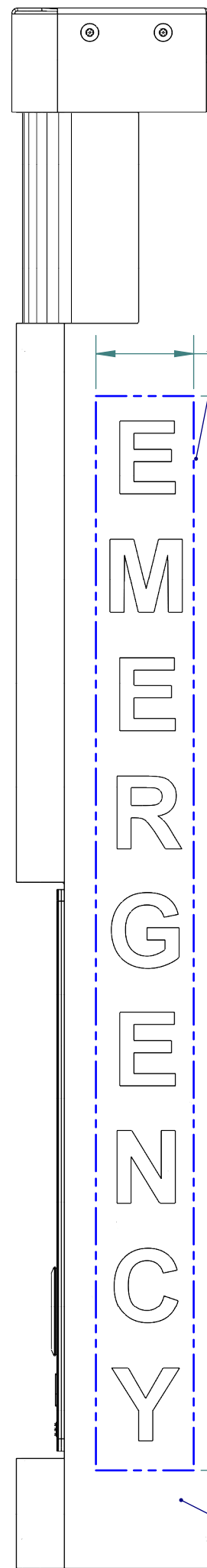

SIDE VIEW

STANDARD SIGNAGE:
SIGNAGE ON TWO SIDES:
2" HIGH REFLECTIVE RED "EMERGENCY"
LETTERING WITH WIDE ANGLE
VISIBILITY IS STANDARD
ALSO AVAILABLE WITH
"ASSISTANCE", "INFORMATION",
OR CUSTOM LETTERING AND COLORS.

2.00 MAX.

22.00 MAX.

STANDARD FINISH:
#4 VERTICAL BRUSHED STAINLESS STEEL

OPTIONAL FINISH:
AVAILABLE PAINTED IN CUSTOM COLORS

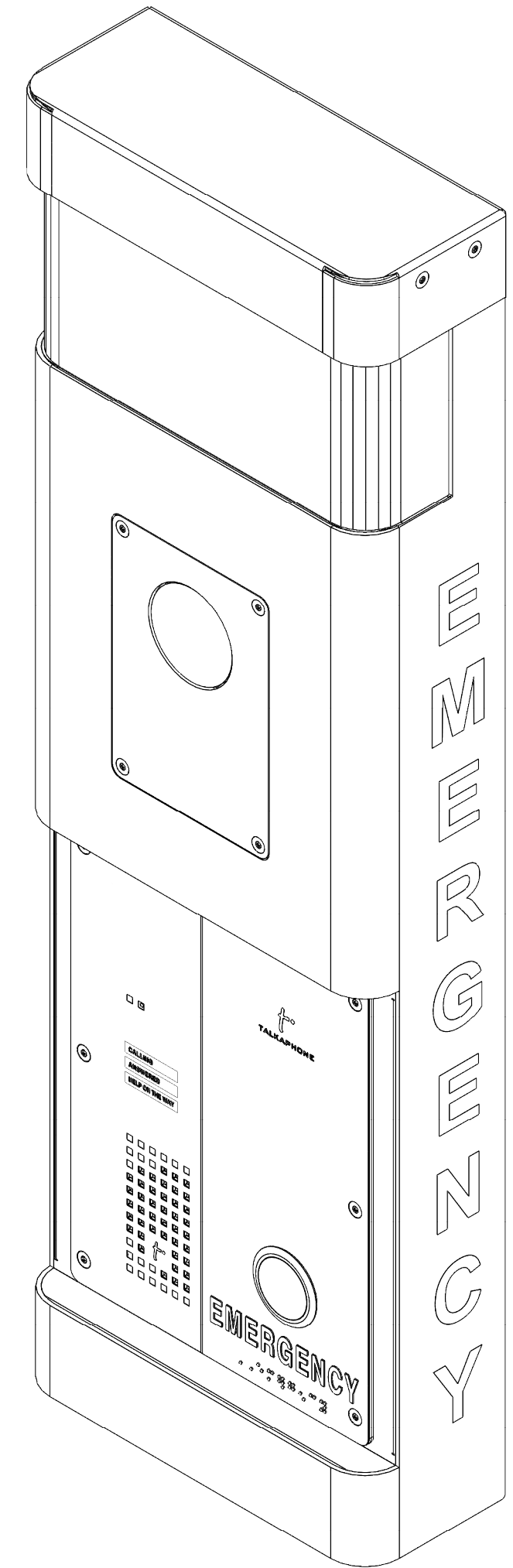

F

E

D

C

B

A

8

7

6

5

4

3

2

1

FINISH
PROPRIETARY AND CONFIDENTIAL
THE INFORMATION CONTAINED IN THIS
DRAWING IS THE SOLE PROPERTY OF
TALK-A-PHONE COMPANY. ANY
REPRODUCTION IN PART OR AS A WHOLE
WITHOUT THE WRITTEN PERMISSION OF
TALK-A-PHONE COMPANY IS PROHIBITED.

	NAME	DATE
DRAWN	K PATEL	03/16/2016
CHECKED	C WONG	03/16/2016
ENG APPR.		
MFG APPR.		
Q.A.		

t.
TALKAPHONE
TALK-A-PHONE CO.
7530 N. NATCHEZ AVE., NILES, IL 60714
WWW.TALKAPHONE.COM

SIZE	PART NO.	ETP-WMS-OP2/OP3IP	REV
C			1.2
SCALE: 1:8		WEIGHT:	SHEET 2 OF 4

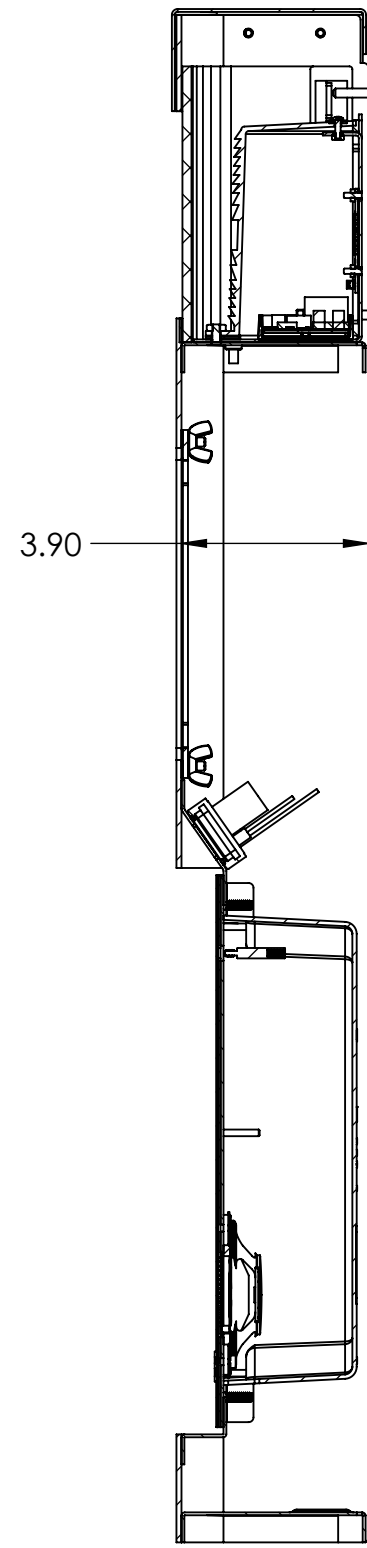

SECTION B-B
SCALE 1 : 4

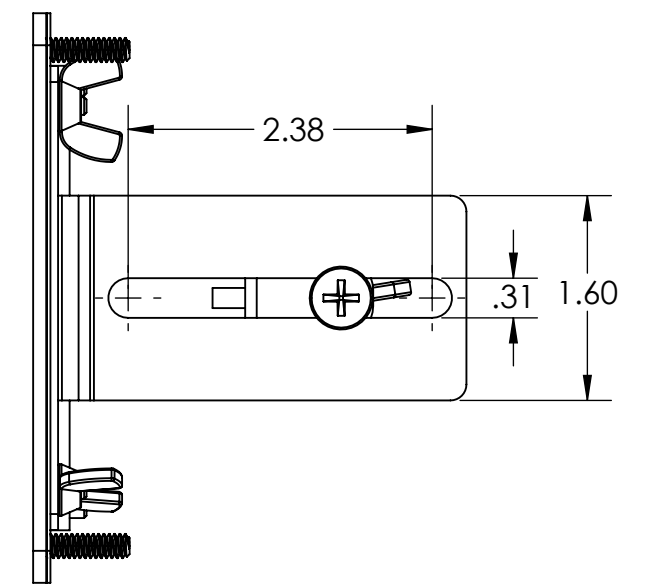
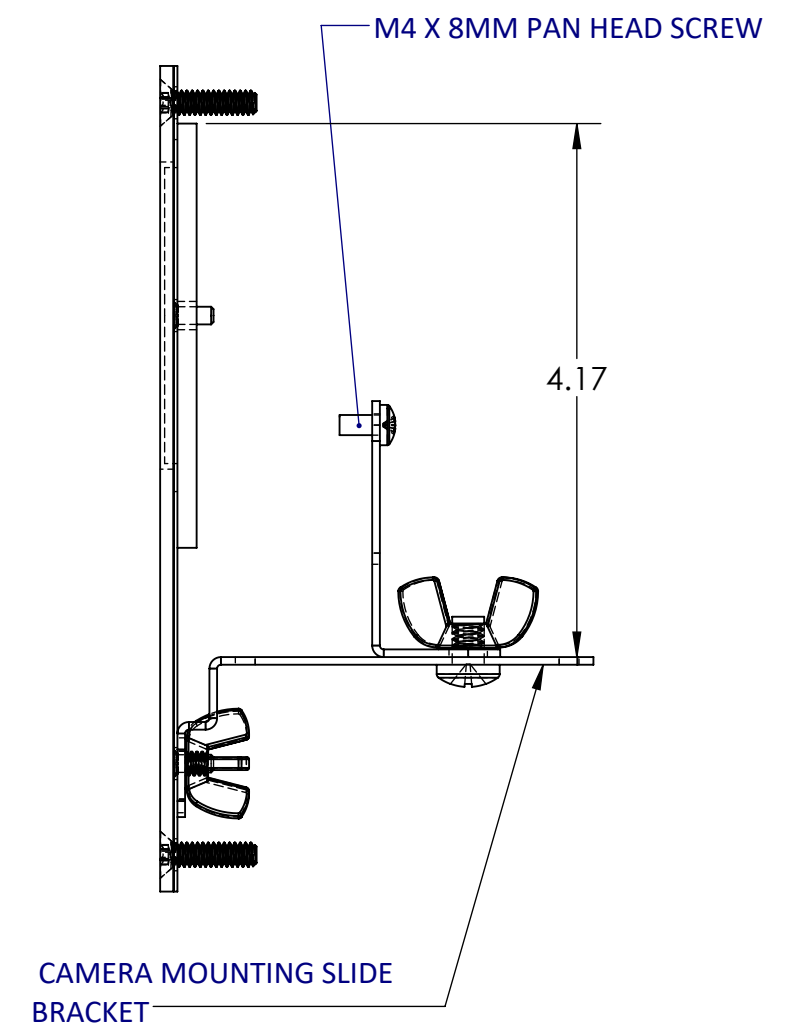
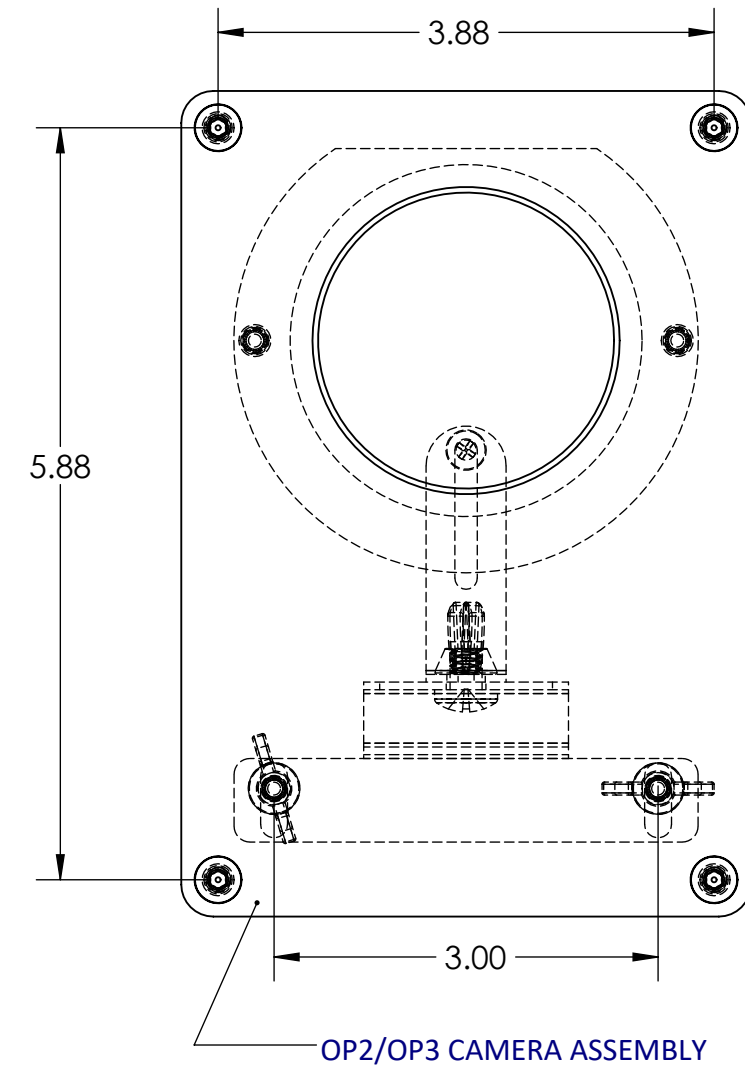
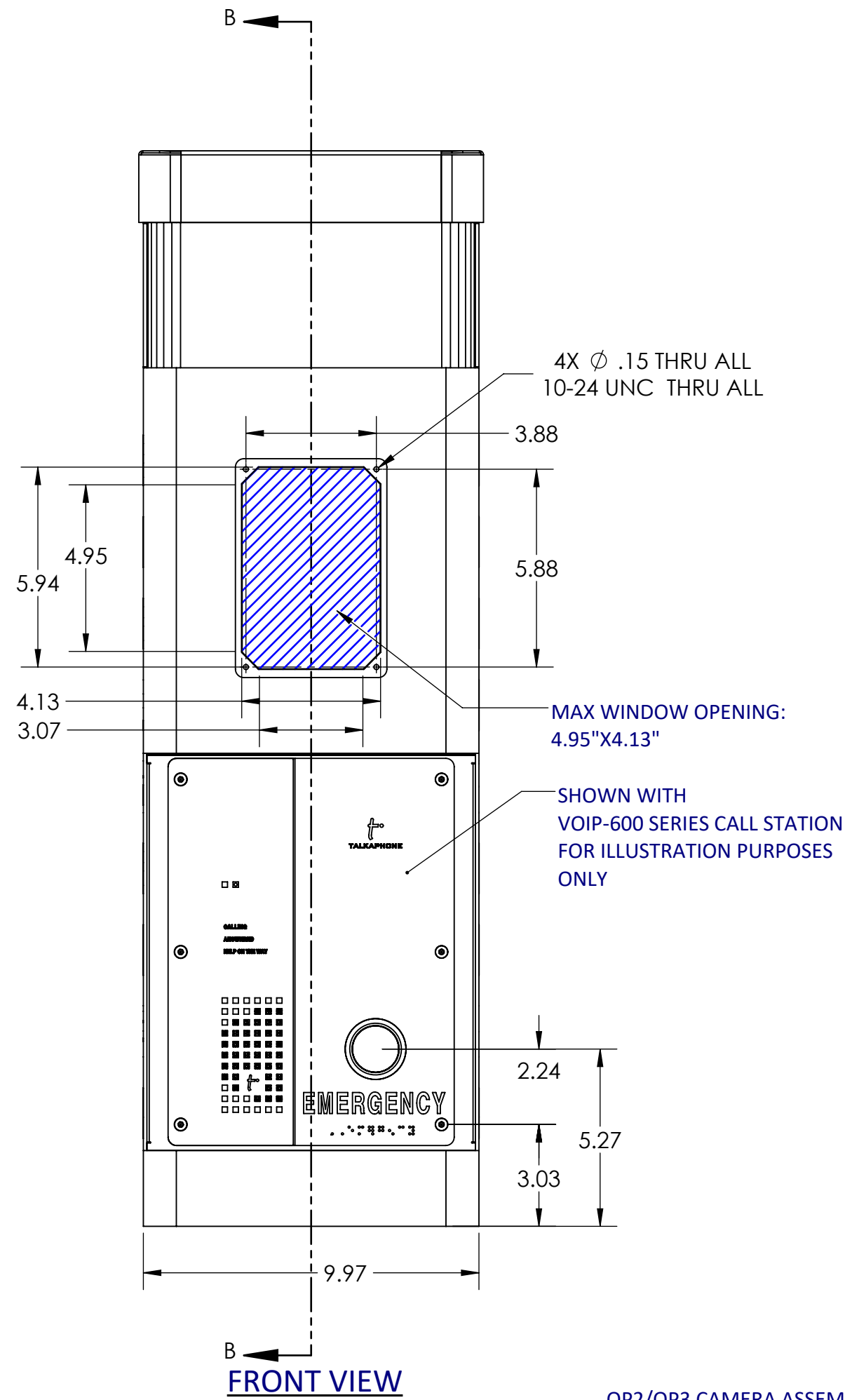

OP2/OP3 CAMERA ASSEMBLY

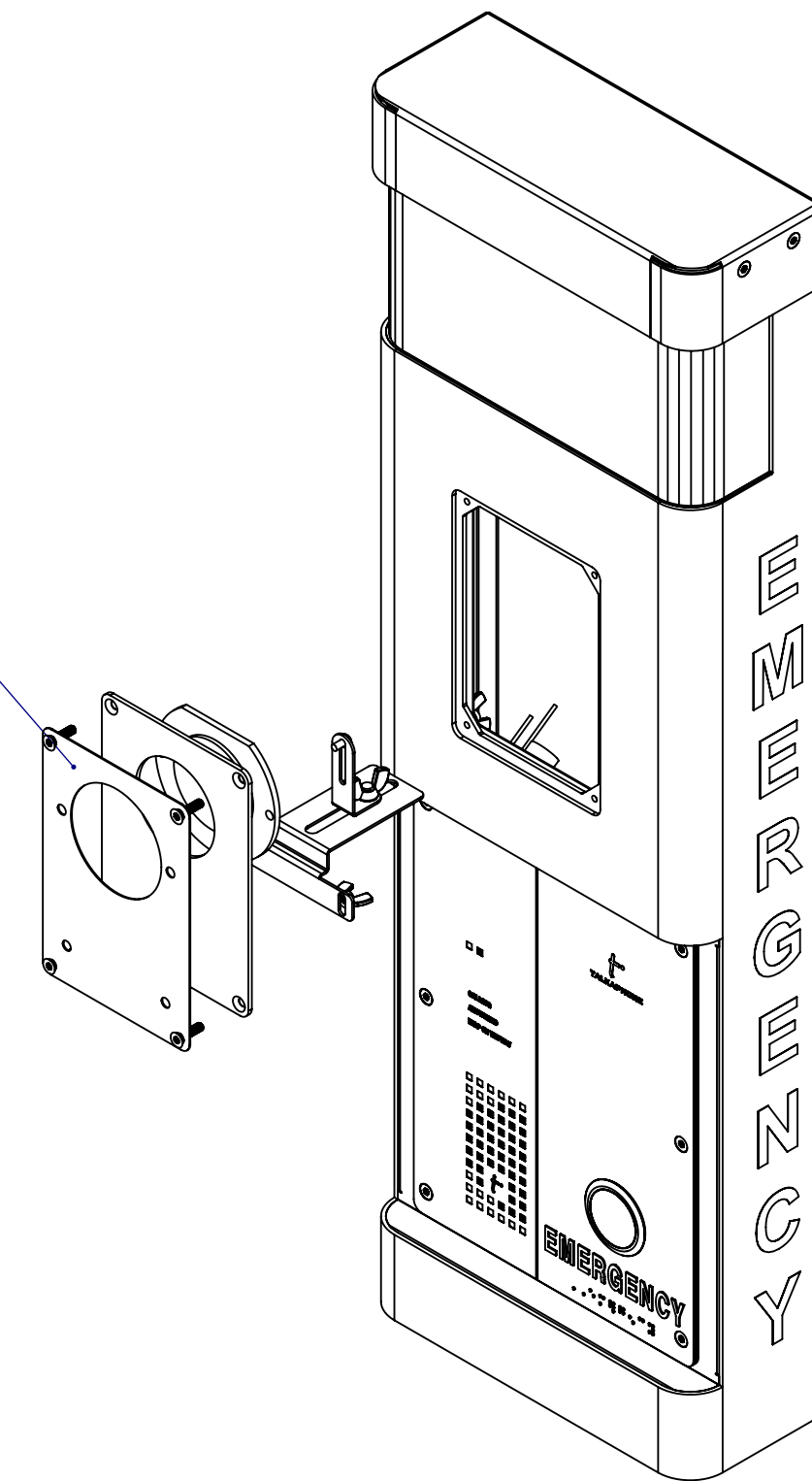

-OP2:
INCLUDES A HOUSING FOR MOUNTING YOUR OWN FIXED CCTV CAMERA (STAND FORM FACTOR WITH MAXIMUM CAMERA DEPTH OF 3.5 IN.) INSIDE THE WALL MOUNT ABOVE THE EMERGENCY PHONE FACEPLATE. INQUIRE FOR FURTHER DETAILS

-OP3IP:
INCLUDES AN AXIS M1025 NETWORK CAMERA INSIDE THE WALL MOUNT ABOVE THE EMERGENCY PHONE FACEPLATE.

FINISH

PROPRIETARY AND CONFIDENTIAL
THE INFORMATION CONTAINED IN THIS DRAWING IS THE SOLE PROPERTY OF TALK-A-PHONE COMPANY. ANY REPRODUCTION IN PART OR AS A WHOLE WITHOUT THE WRITTEN PERMISSION OF TALK-A-PHONE COMPANY IS PROHIBITED.

	NAME	DATE
DRAWN	K PATEL	03/16/2016
CHECKED	C WONG	03/16/2016
ENG APPR.		
MFG APPR.		
Q.A.		
COMMENTS:		

t.
TALKAPHONE
TALK-A-PHONE CO.
7530 N. NATCHEZ AVE., NILES, IL 60714
WWW.TALKAPHONE.COM

SIZE	PART NO.	ETP-WMS-OP2/OP3IP	REV
C	DWG. TITLE:	ETP-WMS SERIES	1.2
SCALE: 1:8	WEIGHT:		SHEET 3 OF 4

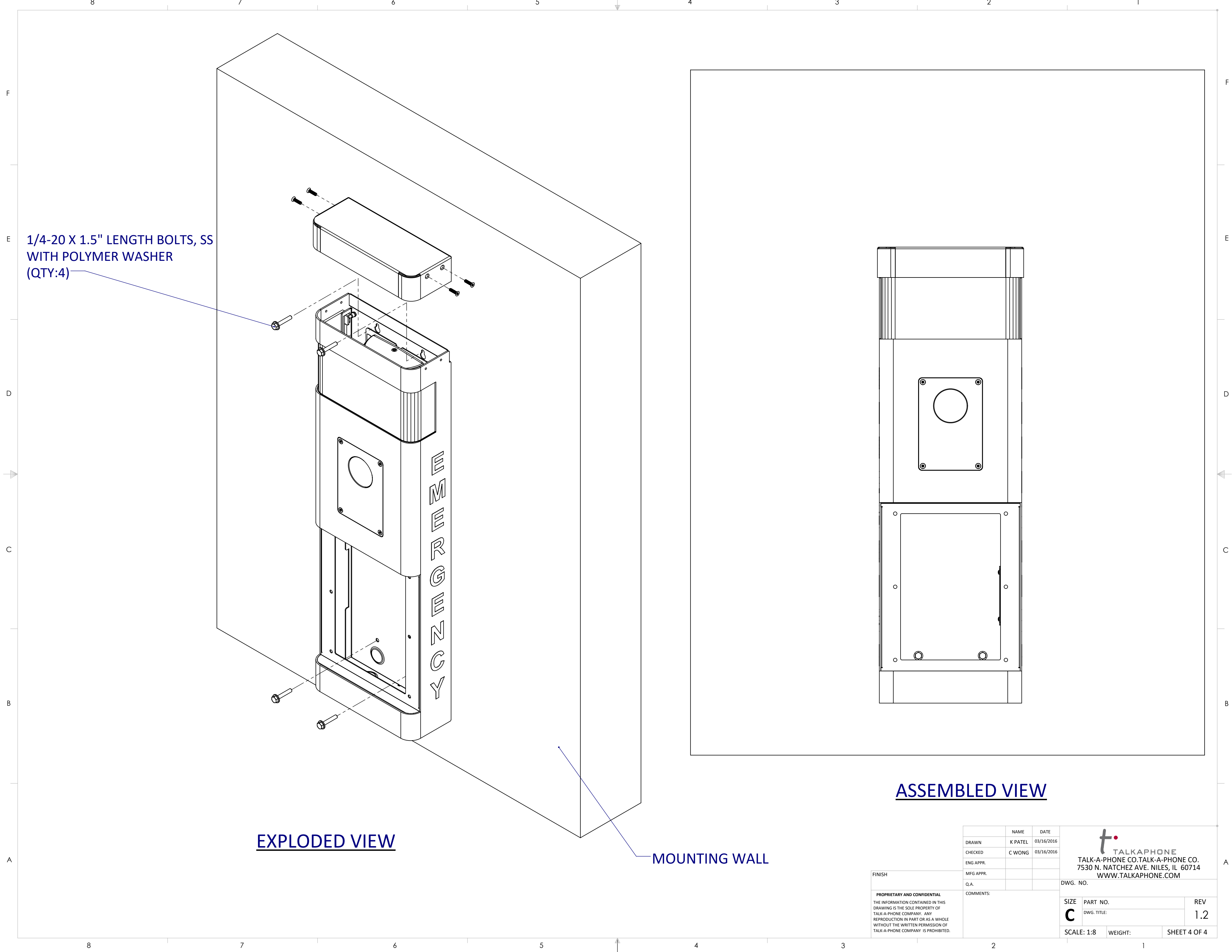

1/4-20 X 1.5" LENGTH BOLTS, SS
WITH POLYMER WASHER
(QTY:4)

EXPLODED VIEW

MOUNTING WALL

ASSEMBLED VIEW

FINISH	PROPRIETARY AND CONFIDENTIAL THE INFORMATION CONTAINED IN THIS DRAWING IS THE SOLE PROPERTY OF TALK-A-PHONE COMPANY. ANY REPRODUCTION IN PART OR AS A WHOLE WITHOUT THE WRITTEN PERMISSION OF TALK-A-PHONE COMPANY IS PROHIBITED.	<table border="1"> <tr> <th>NAME</th> <th>DATE</th> </tr> <tr> <td>DRAWN K PATEL</td> <td>03/16/2016</td> </tr> <tr> <td>CHECKED C WONG</td> <td>03/16/2016</td> </tr> <tr> <td>ENG APPR.</td> <td></td> </tr> <tr> <td>MFG APPR.</td> <td></td> </tr> <tr> <td>Q.A.</td> <td></td> </tr> </table>	NAME	DATE	DRAWN K PATEL	03/16/2016	CHECKED C WONG	03/16/2016	ENG APPR.		MFG APPR.		Q.A.		 <p>TALKAPHONE TALK-A-PHONE CO. TALK-A-PHONE CO. 7530 N. NATCHEZ AVE. NILES, IL 60714 WWW.TALKAPHONE.COM</p>	<table border="1"> <tr> <td>DWG. NO.</td> <td>REV</td> </tr> <tr> <td></td> <td>1.2</td> </tr> </table>	DWG. NO.	REV		1.2
NAME	DATE																			
DRAWN K PATEL	03/16/2016																			
CHECKED C WONG	03/16/2016																			
ENG APPR.																				
MFG APPR.																				
Q.A.																				
DWG. NO.	REV																			
	1.2																			
<table border="1"> <tr> <td>SIZE</td> <td>PART NO.</td> <td>REV</td> </tr> <tr> <td>C</td> <td></td> <td>1.2</td> </tr> </table>		SIZE	PART NO.	REV	C		1.2	<table border="1"> <tr> <td>SCALE: 1:8</td> <td>WEIGHT:</td> <td>SHEET 4 OF 4</td> </tr> </table>		SCALE: 1:8	WEIGHT:	SHEET 4 OF 4								
SIZE	PART NO.	REV																		
C		1.2																		
SCALE: 1:8	WEIGHT:	SHEET 4 OF 4																		